

We, the undersigned, hereinafter referred to as Exhibitor, do hereby submit our application for the reservation of display space as an exhibitor in the **SUPPLYSIDE MARKETPLACE**, subject to all terms, conditions and regulations governing the Expo and its production as set forth on the second page of this contract.

(Please Type or Print Clearly)

Date: _____

Company Name: _____

Contact Name: _____ E-Mail Address: _____

Show Coordinator (exhibitor kit will be e-mailed to this person): _____

*Show Coordinator E-Mail Address: _____

Street Address: _____

City, State, Zip: _____

Phone: _____ Fax: _____

Billing address if different from above: _____

Please indicate companies you DO NOT wish to be placed near on the Exhibit Floor: _____

This application becomes a contract upon acceptance by Expo Management. Contact the Expo Office with any questions concerning Expo arrangements. Please fill out the above and send the application with your deposit check/credit card to: Virgo Publishing, LLC, Dept. 999243, P.O. Box 29042, Phoenix, AZ 85038-9042. **Phone (480) 990-1101 ext. 1171 or 1271. Fax (602)567-6890.**

By signing below, Exhibitor and/or Agency representative acknowledges and confirms that he/she has read the entire Exhibit Application/Contract, including the attached Rules and Regulations provided on a separate page, understands that each forms an integral part of this Exhibit Application/Contract and agrees to be bound by the entire Exhibit Application/Contract.

Signature: _____ **Date:** _____

Fees Schedule - SupplySide Marketplace, May 9-10, 2012, Javits Center, New York, NY - All booth(s) are 10'x10'

FULL PAYMENT AND CERTIFICATE OF INSURANCE MUST BE RECEIVED BY JANUARY 6, 2012.

Booth Price: \$4693

Invitation Package Includes: 100 sq. feet of exhibit space, 4 invitation letters (additional letters are \$30 each), and general liability insurance coverage for duration of show.

Booth Price: \$6,700

Full Booth Includes: 100 sq. feet of exhibit space, modular booth shell with sign, carpet, 4' table or 30" round table, 2 chairs, wastebasket, 2 spotlights, electricity (during show hours only), 4 invitation letters (additional letters are \$30 each), and general liability insurance coverage for duration of show.

Premium Fees: Corner Premium \$200 Island Premium \$1,200

Total # of booths _____ X _____ Booth Price + Corner/Island Premium = **Total Booth Fees** \$ _____

Total booth fees x 50% = **Deposit Due** \$ _____

BOOTH DEPOSITS ARE DUE WITH RETURN OF EXHIBIT CONTRACT.

Method of Payment

Visa MasterCard AmEx Check (make payable to Virgo Publishing LLC)

CC #: _____ Exp. Date: _____

Name On Card: _____ Signature: _____

Date: _____ **Total amount to be charged to credit card at time of contract execution:** \$ _____

Please use the credit card provided above to charge my booth space balance on January 6, 2011 **Initials:** _____

DO NOT COMPLETE BELOW THIS LINE. FOR EXPO MANAGEMENT USE ONLY

SupplySide Marketplace	# of Booths	Confirmed Booth Space	Date Deposit Rec'd	Type of Payment	Date Balance Rec'd	Type of Payment
Javits Center				CC Check#		CC Check#

Floor Plan	Address	Lists	AE

1. PAYMENT

A 50% deposit of total booth fees must be sent to Virgo Publishing, LLC (hereafter referred to as "Expo Management"), along with the signed Agreement. The remaining balance is due and payable on or before Jan. 6, 2012, and is a condition to the continued reservation of the Exhibit Space. All deposits and payments are non-refundable. An exhibitor that downsizes its booth space on or before January 6, 2012 will forfeit its deposit per single booth downsized. An exhibitor that downsizes its booth space after January 6, 2012 will be charged a fee equal to 100% of the booth space being downsized.

2. OUTSTANDING BALANCES

In the event exhibitor has any advertising balances past due two months prior to the Expo, pursuant to any advertising agreement entered between the Exhibitor and Expo Management, Expo Management may cancel the agreement and exclude the exhibitor from the Expo, unless the exhibitor brings its account current immediately.

3. EXHIBITS

Exhibits will be arranged as not to obstruct the general view nor hide the exhibits of others. A plan for specially built displays, not in accordance with Expo regulations, must be submitted to Expo Management at least sixty (60) days before the start of the Expo. Expo Management will attempt to accommodate exhibitor's request for a specially built display, but Expo Management retains sole discretion whether to permit a specially built display.

SupplySide Marketplace Hall Schedule***Set-up**

May 8 8am-5pm
May 9 8am-10am

Show Hours

May 9 10:30am-5pm
May 10 10:30am 4:30pm

Move-Out

May 10 4:30pm-8:30pm
May 11 8-10am

* Subject to Change

Booth Space

Booth includes the following exhibit equipment: 8' high back-drape wall, 36" high side rail, 7"x44" id sign. Exhibit booths are 10'x10'.

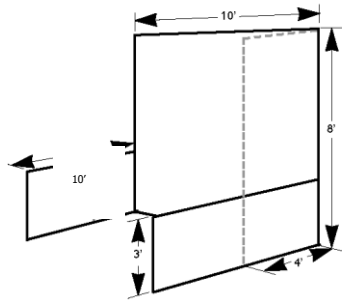
**Standard Booth Exhibits**

Unless express written permission to the contrary is secured from Expo Management in advance, regular and specialty built backwalls, including signs, may not exceed an overall height of 8' and must be freestanding. Low side dividers between exhibits should not exceed 36" in height. If a high divider is desired, it shall not exceed 8' in height or extend from the backwall more than 4'. See drawing.

Island Space

Must be a minimum of 4 booth units. Does not include any backwalls. Island space exhibit must not exceed 16' height as established by Expo Management. All island exhibitors must submit renderings with dimensions to Expo Management for approval 60 days before the Expo.

Assignment and Relocation of Exhibits

Expo Management reserves the right to make the final determination of all space assignments in the best interest of the exposition. Expo Management may alter the location of exhibit spaces, at its sole discretion in the best interest of the exposition.

Operation

Exhibitor will keep exhibit(s) open and staffed at all times during the Expo hours. The Expo Management reserves the right to restrict exhibit to a minimum noise level and to suitable methods of operation and display of materials. If for any reason Expo Management deems an exhibit or its contents objectionable, the exhibit will be subject to removal. This reservation includes persons, things, conduct, printed matter, or any items that Expo Management considers objectionable to the Expo's well being. In the event an eviction or restriction is enforced, Expo Management will not be liable for refunding rental fees or funds for exhibit equipment rental. Exhibitor agrees that Expo Management may substitute the actual space assigned to exhibitor if necessary.

Installation and Dismantling

Information on installation and dismantling of exhibits will be sent to the Exhibitor. Exhibitor agrees to abide by the schedule for set-up and teardown as outlined above. Exhibitor shall be liable for monetary damages caused to Expo Management as result of its delay. No exhibitor shall remove any part of its booth's display until the Expo is officially closed. Exhibitors shall be responsible for any expenses incurred by Expo Management caused by their delay in removing its equipment. Exhibitors must not injure or deface property, including but not limited to, the property of Javits Center, Expo Management and other exhibitors. Should exhibitor cause any property damage, the exhibitor will be solely liable to the damaged party.

Unoccupied Space

Expo Management reserves the right, should any exhibitors' space remain unoccupied on the opening day of the Expo, or should any space be forfeited for any other reason, to re-rent said space to any other exhibitor, or use said space in any other manner. This clause shall not be construed as affecting the obligation of the exhibitor to pay the full amount specified in its invoice for space rental.

4. FIRE, SAFETY AND HEALTH REGULATIONS

Exhibitor agrees to comply with local, city and state laws, ordinances and regulations and the regulations of the owner of the Exhibit Hall and/or Expo Management covering fire, safety, health and all other matters. All exhibit equipment and materials will be reasonably located within the booth and protected by safety guards and devices where necessary. Only fireproof materials should be used in displays and all necessary fire precautions must be taken by the exhibitor.

5. LABOR

Local unions make rules and regulations for union labor and these regulations may be changed at any time. Where union labor is required because of building or contractor requirements, exhibitor agrees to comply with the union rules and regulations.

6. SUBLETTING OF SPACE

The exhibitor shall not assign, sublet, or apportion the whole or any part of the space assigned, or have representatives, equipment, or materials from firms other than his own in the exhibit space without prior written consent of Expo Management.

7. SERVICE CONTRACTORS

When a contractor has been designated by Expo Management to perform services for exhibitors such as rental of furniture, erection of exhibits, electrical work, plumbing, labor, or any other service, no exhibitor or representative shall contract for such services with other than the said official contractor unless permission has been secured in writing in advance from Expo Management.

8. LIABILITY EXCLUSION

Expo Management will employ guards and will take reasonable precaution to safeguard the exhibitor's property. However, Expo Management will not be liable for loss or damage to the property of the exhibitor or his representatives or employees from theft, fire, accident or any other cause beyond its control. Exhibitor agrees to protect, save and hold the Expo Management, the Mayor and City Council of New York, NY and the Javits Center and all agents and employees thereof (hereinafter collectively called Indemnities), forever harmless for any damages or charges imposed for violations of any law or ordinance, whether occasioned by the negligence of the exhibitors or those holding under the exhibitor, and save, and hold harmless the Indemnities against and from any and all losses, costs, damage, from or out of or by reason of any accident or bodily injury or other occurrence to any person or persons, including the exhibitor, its agents, employees, and business invitees which arises from or out of or by reason of said exhibitor's occupancy and use of the exhibition premises, the hotel, or any part thereof.

9. MANDATORY INSURANCE

Exhibitors shall carry and maintain during the period of the Expo, including set-up and teardown days, and at his sole cost and expense, personal injury and property damage coverage under a policy of general public liability insurance. The policy must have limits of at least \$1,000,000 combined single limit for bodily injury and property damage, and name Virgo Publishing LLC as Certificate Holder and as an additional insured. Exhibitors must furnish a copy of its Certificate of Insurance meeting the above stated requirements by January 6, 2012. If a Certificate of Insurance is not provided by the above-mentioned deadline, exhibitor will forfeit its 50% deposit and not be allowed to exhibit at the Expo. Exhibitor warrants and represents that by signing this Agreement it will comply with the insurance requirements stated in this Paragraph.

10. UTILITIES

Expo Management shall use reasonable care to have all power services installed in time for the opening of the Expo. Proper and reasonable care shall also be taken to prevent the interruption of power services during the exhibition. However, Expo Management shall not be held responsible for late installation or interruption of any services that may occur.

11. CANCELLATION / POSTPONEMENT

If Expo Management is prevented from holding the Expo, due to circumstances beyond its control, including, but not limited to strike, civil disobedience, and/or acts of God, Expo Management shall have the sole and absolute right to cancel or postpone the Expo. If the Expo is canceled, Expo Management will refund to the exhibitor the amount of the rental paid by him, less a proportionate share of the Expo expenses, and if the exhibitor made no rental payment, he nevertheless shall be obligated to pay his proportionate share of such expenses. If the Expo is postponed, the exhibitor's obligations will remain the same under this Agreement as if the Expo was held as scheduled. Whether an Expo is canceled or postponed, Expo Management shall have no further obligation or liability to the exhibitor.

In addition, Expo Management reserves the right to terminate this contract at any time prior to the Expo. If this contract is terminated, Expo Management will refund the amount paid by the exhibitor less any expenses incurred by Expo Management in the termination.

12. RULES AND REGULATIONS

Expo Management shall have full power in the interpretation and enforcement of all rules contained herein. Expo Management may make such further rules and regulations, as it shall consider appropriate for the proper conduct of the Expo.

13. CHOICE OF LAW, JURISDICTION AND ATTORNEY'S FEES

The validity, interpretation and performance of this Agreement shall be governed by and construed in accordance with the laws of the State of Arizona. Every dispute concerning the interpretation, effect of breach of this Agreement shall be resolved in the Superior Court of Arizona, County of Maricopa. To the maximum extent permitted by law, each party agrees to personal jurisdiction, subject matter jurisdiction and venue of such Court. In any action upon this Agreement, the prevailing party shall be entitled to reasonable attorney's fees and cost, as determined by the Court.

14. TAXES AND LICENSES

Exhibitor shall be responsible for obtaining any licenses, permits, or approvals required under local or state law applicable to their activity at the Expo. Exhibitor shall be responsible for obtaining tax identification numbers and paying all taxes, license fees or other charges that shall become due to any government authority in connection with their activities at the Expo.

15. PHOTOGRAPHY/VIDEO/RECORDING/LIGHTING ON EXPO FLOOR

No exhibit, performance or event presented at the Exposition shall be photographed, videotaped, broadcast or recorded for commercial use, sale or distribution of any kind without the express written consent from management of the Expo. Exhibitor/Vendors shall not photograph or videotape the exhibit/presentation or product of another Exhibitor/Vendor. The Lighting of any fluorescent bulbs (UV emitting or not) is strictly prohibited on the Expo floor. This includes bulbs to be lit for demonstration purposes (standard booth lighting is permitted).

16. ATTENDEE LIST

The Expo Management may make the attendee list available after the Expo, but reserves the right to limit the distribution of the attendee list to persons or entities that they deem are not competitors of Expo Management. The Expo Management may also restrict the form and transferability of the attendee list.

17. SMOKING

The Expo is a non-smoking conference. Smoking is only permitted in areas *outside* the Expo as designated by the Expo Hotel/Facility.